

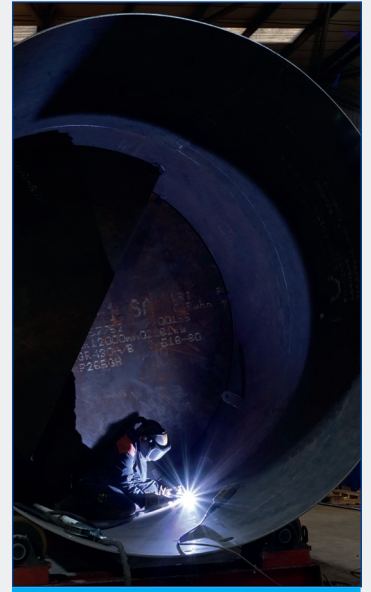

Data Centre Vessels



- Large volume thermal stores to cover critical cooling system failures
- Compliance with European PED standards
- Applications up to 30 bar(g)



Leading the Field in Innovative Technology

Contents

Page 1	What we do
Page 2	A Chilled Buffer Vessel Journey
Page 3	DCV Data Centre Vessels
Page 3	Standards & Codes
Page 4	Make up of a Vessel
Page 5	Optional Vessel Components
Page 6	Sizing Chart
Page 7	Designs
Page 8	Design Space
Page 9	Sectional Vessels
Page 9	Frost Protection
Page 10	Information required for a Chilled Vessel Proposal
Back	Transportation

Our team at Ormandy Rycroft is dedicated to customer service and will advise you on the most efficient solution bespoke to your individual requirements.

As a leading manufacturer of Instantaneous Water Heaters and Commercial Heating & Cooling Solutions, we pride ourselves on our industry knowledge and the high standards and expertise you expect from an industry leader.

Consultation



Advice from our experienced Sales Team across the UK

Bespoke Design

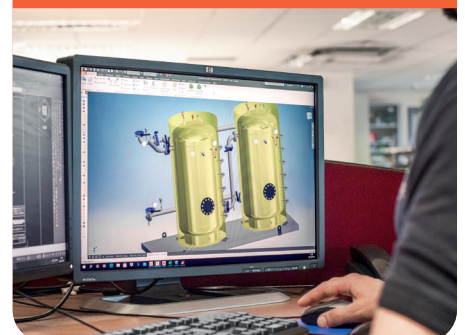

Tailored Engineering Design Specification & Development

Every Industry



From HEVAC to Process, we cover all Industry Sectors

Manufacturing Excellence



Leading the field in Innovative Engineering Solutions

Aftercare



Reliable Commissioning, Maintenance and Servicing

Our technical knowledge is second to none and we take pride in nurturing and growing our relationship with customers through advice and support before, during and after installation.

At Ormandy Rycroft, nothing is standard. From our service to you, to the quality control of our products, we aim to exceed your expectations at every stage of the process.

Our manufacturing facilities are world class and we are one of only a handful of companies who have the ability to manufacture both copper and copper lined vessels, as well as high specification stainless steel vessels for industries requiring a more specialised design for Process Solutions.

Whatever your heating and cooling needs, you won't make a better start than by making Ormandy Rycroft your first port of call.

1. Manufacturing of a Vessel

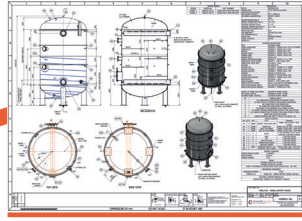
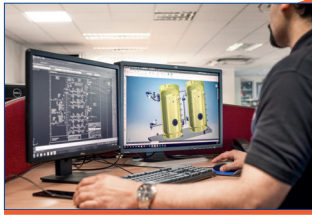

A Chilled Buffer Vessel Journey

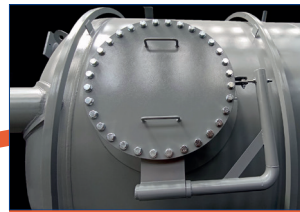

Insulation Rings/
Trace Heating is an
optional extra

2. DCV Data Centre Vessels

The Ormandy Rycroft DCV's are bespoke, designed and manufactured to the specification required in our UK factory in Bradford. Available up to capacities of 70m³, they can be sited internally or externally if required.

As standard, all our vessels are fully compliant under "Sound Engineering Practice (SEP), category of the UK Pressure Equipment (Safety) Regulations 2016 or the EU Pressure Equipment Directive 2014/68/EU. If required, we can also build to Design Codes PD5500, EN13445 or ASME VIII.

Features & Benefits

- **Capacities** - Available up to circa 70m³ (if larger vessels are required, we can review these on a job by job basis)
- **Materials** - Available in Carbon Steel or Stainless Steel (304L, 316L or LDX)
- **Orientation** - Can be designed Vertically or Horizontally
- **Siting** - If Internal Space is limited, they can be manufactured for External Use
- **Sectional** - Ideal for Restricted Access or for Replacement Strategy
- **Design Code** - We can manufacture to PD5500, EN13445 or ASME VIII
- **Paint Coatings** - Available from Standard Red Oxide to External Coatings C3-C5, dependant on external conditions
- **Frost Protection** - Calculated and supplied with either Immersions or Trace Heating
- **Insulation Rings** - Aids the insulation to be installed more easily on site when provided by others



3. Standards and Codes

In the UK, Buffer Vessels must primarily comply with the "Pressure Equipment (Safety) Regulations (PE(S)R) 2016, which implement the European Pressure Equipment Directive (PED) 2014/68/EU.

As well as the above, Ormandy are also able to manufacture to Specific Design Codes:

PD5500 is widely used in the UK and globally. Offering specific requirements for Design, Manufacture, Inspection and Testing of New Unfired Pressure Vessels. (Cat I - 100% NDT / Cat II - 10% NDT and Cat III - no NDT). A "Form X" **must** be supplied with the vessel to be compliant.

EN13445 is the Harmonised European Standard and is often intended for use across the EU.

ASME VIII is the American Society of Mechanical Engineers Code and is often used for projects throughout the world.

4. Make Up of a Vessel

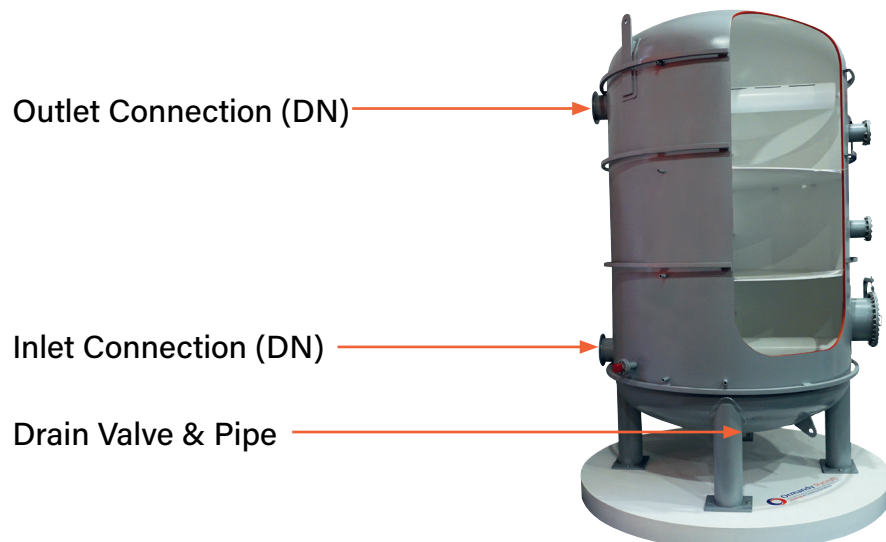
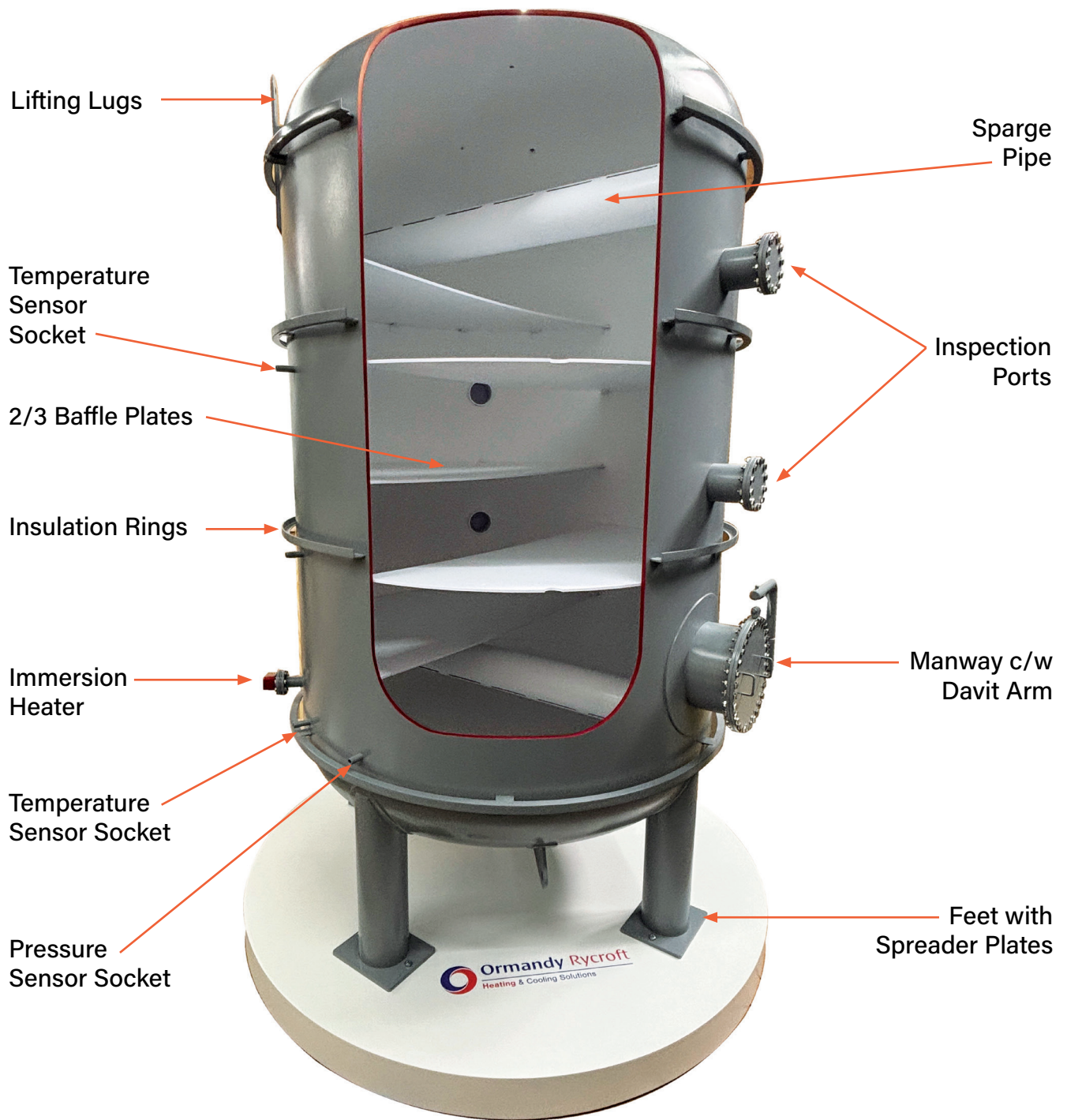

5. Optional Vessel Components

Diffuser

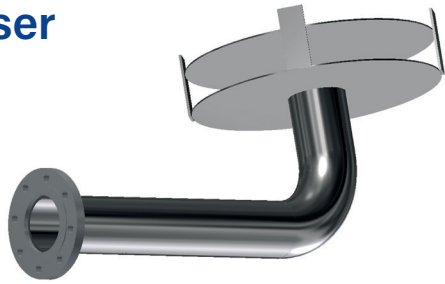

Designed to reduce very high velocities flowing into the vessel, minimising turbulence.

Sparge Pipe



Used to reduce velocities of fluids entering and exiting the vessel.

Baffle Plate 3/4

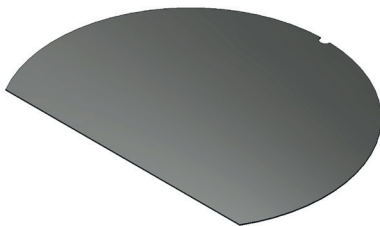

Baffle plates are primarily used to regulate fluid flow and maximise thermal efficiency within the chilled vessel.

Perforated Baffle Plate

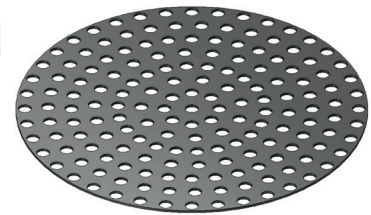

Perforated baffle plates are used to achieve uniform flow distribution and thermal stratification by transforming turbulent intake into a controlled laminar flow. Also used when baffle plates aren't suitable due to spacial constraints.

Dip Pipe

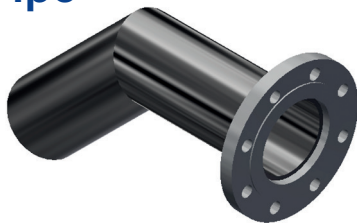

Dip pipes are used to maximise full use of the vessel by steering fluid to the desired areas. They are also used when standard placement of connections can't be achieved due to vessel location.

Manway / Inspection Port



A manway (or manhole) and inspection ports are reinforced access openings required for the safe operation, maintenance and legal compliance of the system.

Manway c/w Davit Arm

A davit arm is a mechanical, support device that allows the safe removal of the manway cover plate.

This is recommended for sizes in excess of 450mm.



Diameter (mm)	Coverplate (mm)	Weight (kg)
100	190	3.34
150	245	5.55
200	330	10.74
250	395	15.38
300	445	23.19
380	520	31.66
455	597	41.73
500	648	49.16
600	750	65.86

6. Sizing Chart

Below is a sizing chart based on a selection of capacities based on a 3:1 ratio. Alternative ratios can be designed and manufactured to meet specific site requirements.

Vertical Options

Volume m ³	Body of Vessel			
	A Diameter mm	B Height mm	Ratio H:D	C Feet* mm
1	800	2131	2.66:1	200
2.5	1050	3074	2.93:1	200
3	1150	3094	2.79:1	200
4	1200	3750	3.13:1	200
5	1350	3733	2.77:1	200
6	1450	3892	2.68:1	200
7.5	1500	4511	3.00:1	200
8	1550	4514	2.91:1	200
9	1600	4758	2.97:1	200
10	1650	4973	3.01:1	200
12.5	1800	5232	2.9:1	200
15	1900	5626	2.96:1	300
17.5	2000	5928	2.96:1	300
20	2100	6147	2.93:1	300
22.5	2200	6308	2.87:1	300
25	2300	6428	2.79:1	300
27.5	2300	7029	3.06:1	300
30	2400	7057	2.94:1	300
35	2500	7571	3.03:1	300
40	2600	7991	3.07:1	300
45	2700	8339	3.09:1	300
50	2800	8615	3.08:1	300



*Depends on the size of the drain valve to height required.

- 1 All measurements don't account for insulation.
- 2 Connections will protrude from the insulation by 15mm for screwed & 65mm for flanged.
- 3 Allow circa 200mm from the top of the vessel for the lifting lugs.

Horizontal Options

Volume m ³	Body of Vessel			
	A Diameter mm	B Length mm	Ratio H:D	C Feet* mm
1	800	2131	2.66:1	200
2.5	1050	3074	2.93:1	200
3	1150	3094	2.79:1	200
4	1200	3750	3.13:1	200
5	1350	3733	2.77:1	200
6	1450	3892	2.68:1	200
7.5	1500	4511	3.00:1	200
8	1550	4514	2.91:1	200
9	1600	4758	2.97:1	200
10	1650	4973	3.01:1	200
12.5	1800	5232	2.9:1	200
15	1900	5626	2.96:1	300
17.5	2000	5928	2.96:1	300
20	2100	6147	2.93:1	300
22.5	2200	6308	2.87:1	300
25	2300	6428	2.79:1	300
27.5	2300	7029	3.06:1	300
30	2400	7057	2.94:1	300
35	2500	7571	3.03:1	300
40	2600	7991	3.07:1	300
45	2700	8339	3.09:1	300
50	2800	8615	3.08:1	300

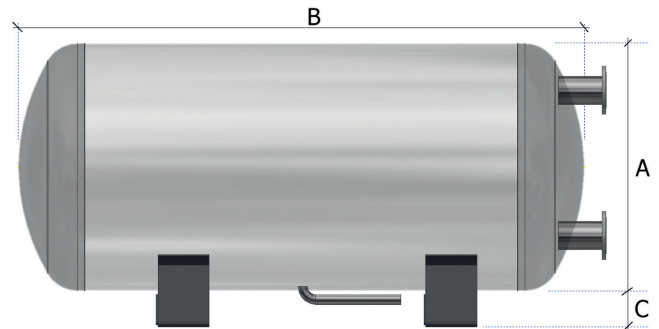

*Depends on the size of the drain valve to height required.

- 1 All measurements don't account for insulation.
- 2 Connections will protrude from the insulation by 15mm for screwed & 65mm for flanged.
- 3 Allow circa 200mm from the top of the vessel for the lifting lugs.

7. Designs

Each Chilled Vessel project can have differing requirements, whether it be orientation (vertical or horizontal), number of connections (2 or 4 pipe), siting (internal or external, or on a concrete base or a steel gantry), flow rates and velocity.

Below Shows how the “internals” of the vessel could change, based on the above and running the simulation through a CFD analysis (Computational Fluid Dynamics).

Typical Vertical Designs

Pre-CFD

Components:

- 2No Sparge Pipes (Inlet & Outlet)
- 2No 2/3rd Baffle Plates
- 2No 450mm Manway
- 1No Inspection Port



Post-CFD

Components:

- 2No Diffusers (Inlet & Outlet)
- 2No Perforated Baffle Plates (hatches included for access through the vessel)
- 2No 450mm Manway
- 1No Inspection Port

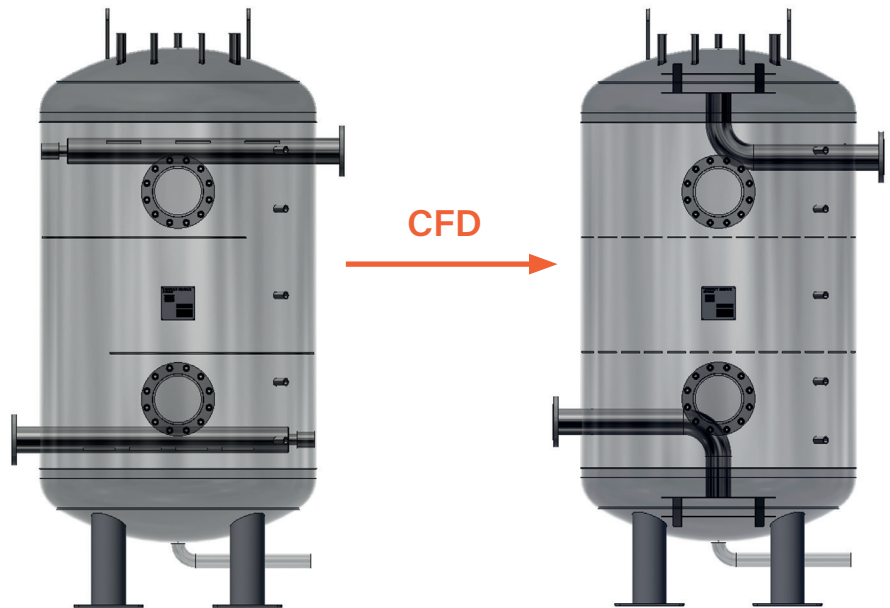

Typical Horizontal Designs

Pre-CFD

Components:

- 1No Sparge Pipes (Inlet)
- 1No Dip Pipe (Outlet)
- 1No Longitudinal Baffle Plate (with Hatch for access to both sides of the vessel)
- 1No 600mm Manway
- 1No Drain Valve & Vents



Post-CFD

Components:

- 2No T - Diffusers (Inlet & Outlet)
- 4No Vertical 3/4 Baffle Plates (Hatches included for access through the vessel)
- 2No 600mm Manways
- 3No Drain Valves & Vents

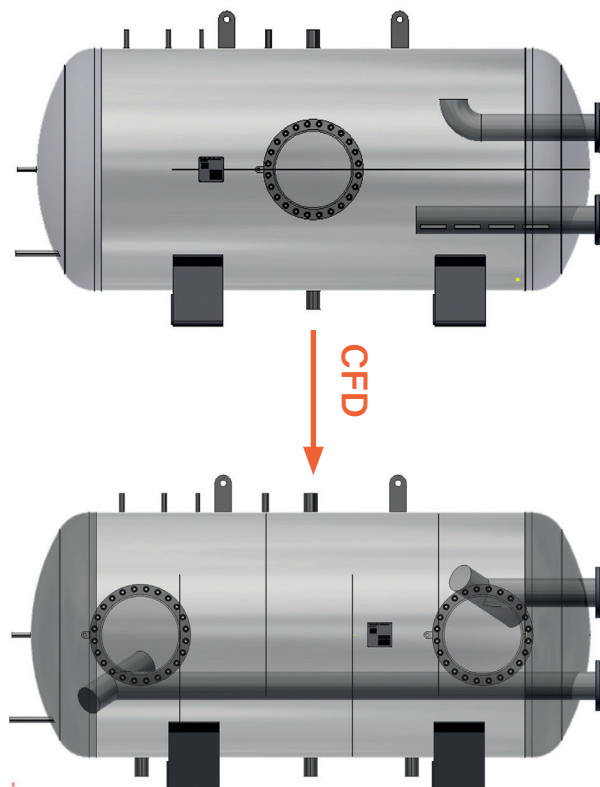

8. Design Space

When looking at the internals of the vessel it is important to understand what space is available, to work out what is required. See below example:

Both the below vessels are 10m³ in capacity.

The vessel on the left matches what was in the specification.

3No 2/3 Baffle Plates & 2No Manway @ 450mm. As you can see, due to the diameter of this vessel, the barrel length is 2500mm, meaning everything specified will fit in the vessel.

However, due to height restraints the diameter of the vessel has had to increase, meaning that the barrel length is now only 1503mm (right image). Because of this, the 3No Baffle Plates won't fit within the space provided, meaning the internals would now have to change to 1No Perforated Baffle Plate and 1No Manway @ 600mm. As the Perforated Baffle Plate covers the whole of the vessel, a cut out would be required so access to both areas of the vessel are achievable.

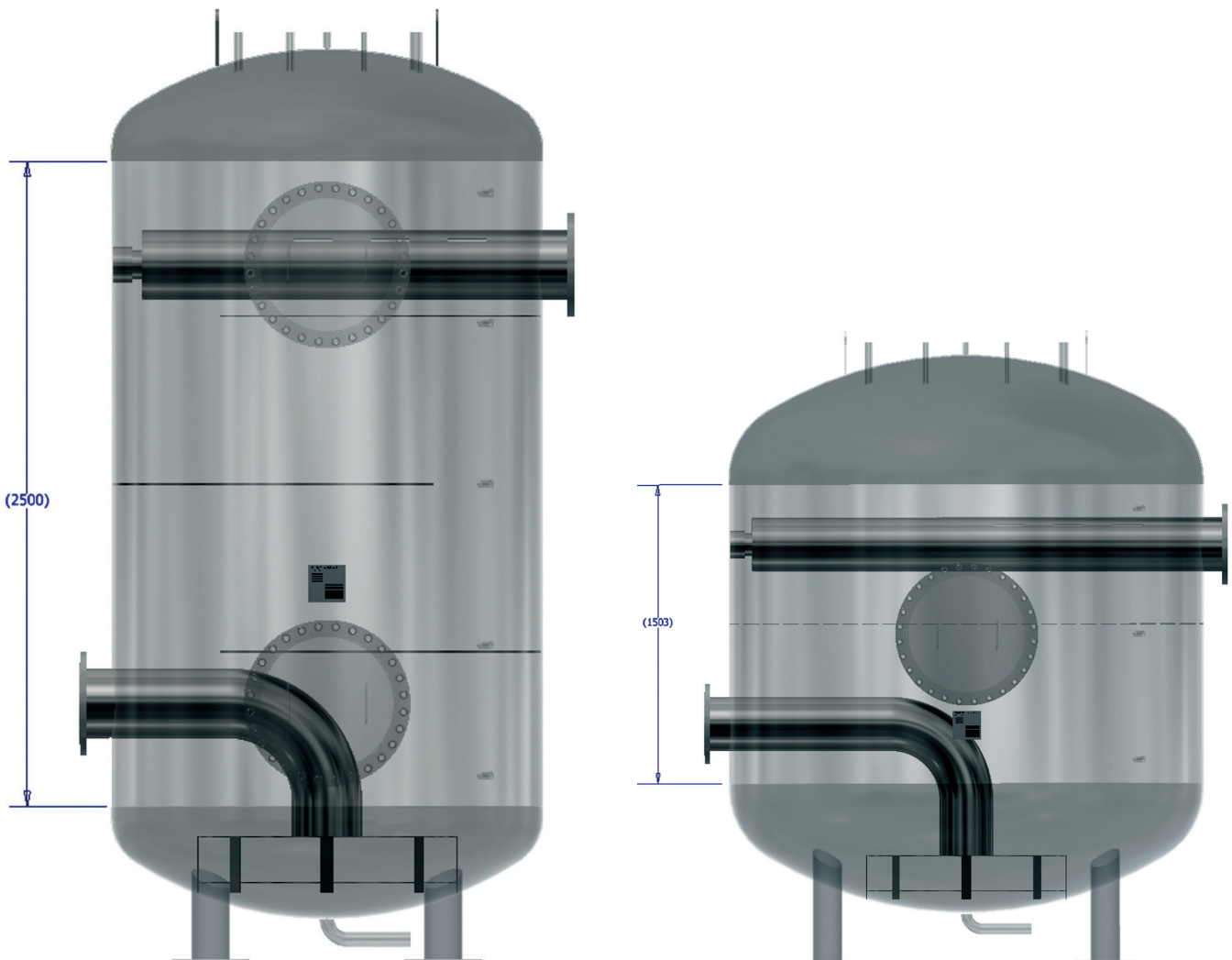

Vessels can be engineered to suit the specific spatial constraints of each project, ensuring optimal integration within the available footprint.

9. Sectional Vessels

The primary benefit of sectional vessels lies in their modular design, allowing them to be transported in pieces and assembled on site.

This offers significant advantages over one piece vessels, especially when access to the required location is restricted. Individual sections can fit through standard doorways, into basements or rooftops, making installation possible in locations that are inaccessible to large pre-built vessels.

Available in vertical or horizontal, the modular nature allows for flexible sizing and configuration to meet specific volume requirements and fit unusual or tight spaces efficiently, which avoids wasted space. Incorporating sectional vessels into new-build systems ensures future replacement requirements are fully accommodated, greatly simplifying the process when the time comes.

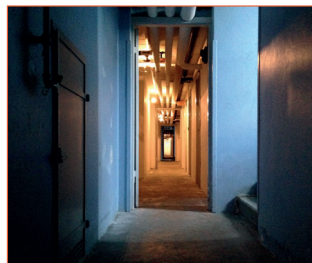

Sectional vessels take into consideration restrictions, such as narrow corridors, space restrictions and small doorways, as well as existing equipment which has been built around the original vessel.



10. Frost Protection

Thermal Insulation (Lagging & Cladding)

This is the first line of defence. Installing high quality insulation to the exterior of the vessel and pipework, helps retain heat and slow down the freezing process. Insulation is then protected by waterproof cladding.

Electrical Trace Heating

This involves running self-regulating heating cables/tapes along the external surface of the vessel, underneath the insulation. A thermostat monitors the temperature and automatically activates the heating element when the temperature drops near freezing, providing heat to prevent ice formation.

Anti-Freeze Solutions (Glycol Blends)

Water in the system is mixed with a specific concentration of inhibited propylene/ethylene glycol to lower its freezing point significantly. Glycol also provides corrosion protection to the system.

Electrical Immersion

This has the same principle as trace heating but via a removable immersion heater sited within the vessel.



11. Information Required for a Chilled Vessel Proposal

Project Name:				
Quantity		No		
Capacity		m3		
Siting	Internal	External		
Orientation	Vertical	Horizontal		
Fluid				
Material	Carbon Steel	S/Steel 304l	S/Steel 316l	S/Steel LDX
Height/Width restrictions		mm		
Design Pressure		bar		
Design Code	PED SEP	PD5500	EN13445	ASME VIII
Primary Connections		No		
Connection Size & Flow Rate	DN			kg/s
Secondary Connections		No		
Connection Size & Flow Rate	DN			kg/s
Insulation Thickness		mm		
Insulation Rings required	YES	NO		
Manway	450	500	600	mm
Quantity		No		
Davit Arm requirements	YES	NO		
Inspection Ports	150	200	300	mm
Quantity		No		
Baffle Plates	2/3	Perforated		No
Sectional	YES	NO		No
Sensors	Temp		Pressure	
Lifting Lugs	Top of Vessel	Y/N	Side of Vessel	Y/N
Shell Fittings	PG	TG	AAV	MAV
	Safety Valve			
Supports	Feet	Ringstand	Cradle	
External Paint	Red Oxide	C3	C4	C5
Frost Protection	Immersion	T/Heating		kW
	External Loading		Ambient Temp	
Access/Height/Footprint Restrictions				
Additional Information				

12. Transportation



- All vessels are delivered by our dedicated haulier team, ensuring arrival at site, to suit critical cranaage and offloading restrictions.
- Deliveries to Europe are offered DAP.
- If the client does not have an import clearing agent, Ormandy can assist through our extensive haulage network. This ensures there are no delays or additional costs with goods held at customs awaiting clearance.



Duncombe Road,
Bradford, England BD8 9TB.

Telephone: +44 (0) 1274 490911. Email: sales@ormandygroup.com

www.ormandygroup.com